



IDEAL IN COOLING & HEATING APPLICATIONS

- » LOWER ENERGY BILLS - SAVE 20-50%
- » LOWER CARBON EMISSIONS
- » SLEEK & UNOBTRUSIVE DESIGN
- » PATENTED FAN TECHNOLOGY
- » OPTIMISED THERMAL COMFORT SUMMER AND WINTER
- » PROVEN ALTERNATIVE TO LARGE BLADED FANS
- » INCREDIBLY FAST ROI

AIRIUS[®]
**AIRFLOW
REINVENTED**





Airius fans are ideal in every industry, as evident from the thousands of businesses we are keeping cool or saving energy, right now. From SMEs to major Blue Chip companies, our fans make impactful cost reductions and optimise comfort while seamlessly improving the design aesthetic, blending into the background.



Table of Contents

AIRIUS - Airflow Reinvented

Reinventing airflow since 2004, Airius have revolutionised the global fan markets with their market leading air circulation and thermal destratification systems. Our Patented Airflow Technology is reinventing the expectations of a fan with amazing outcomes, providing comfort from heat in summer and optimising warmth in cooler environments. Airius fans also provide significant benefits for cold freezer aisles in supermarkets while offering excellent condensation reduction in all building types.

These architecturally designed fans are taking the stage as their sleek design blends into every location with ease and sophistication. As testament to its superiority, the Airius system has quickly built an extensive and prestigious client base including well-known brands shown to the left.

- 04. How Will I Benefit?
Cooling, Heating & Airflow Circulation
- 06. How It Works
Airius' Unique Airflow System
- 08. Patented Technology
Benefits & Savings
- 10. The Standard Series
The World Famous 'Air Pear'
- 12. The Designer Series
The Discreet Solution
- 14. The Retail Series
Increasing In Store Browsing
- 16. The Gem Series
G-Force Velocity For Open Spaces
- 18. The Suspended Series
Cooling or Destratifying Low Profile Areas
- 20. The Quiet Series
For Noise Sensitive Applications
- 22. The Pearl Series
For Small - Medium Sized Spaces
- 23. The Opal Series
Reinventing Home Cooling & Destratification
- 24. The Onyx Series
Innovative New Airflow Methodology
- 26. Our Full Product Range
Unit Dimensions & Weights
- 28. Technical Data
Fan Model, Motor & Coverage Data
- 32. Project Gallery
- 34. Customer Testimonials
- 36. Contact Information

How will I benefit?

Airius' Airflow Technology uses a unique air turbine that has created a new standard in fan airflow expectations. The patented design enables movement of large amounts of air, over long distances, vertically or horizontally, using very low amounts of energy.



Cooling & Comfort

The circular or elongated air flow pattern options allows the air direction and placement to be controllable by you, based on your specific environment. This unique feature allows you to cool staff, products and large communal areas in a highly targeted way, producing immediate results. Cool people = Happy people.

Research indicates that the Airius patented airflow system can help your staff / customers feel up to 7°C cooler on a 35°C day with 70% humidity!

Supporting Air-Conditioned Spaces

In Australia, air-conditioning is a costly summer must in many work spaces. Airius fans help optimise A/C performance and reduce operational costs by reducing run time and workload.

In air-conditioned environments, the chilled air is rapidly circulated by Airius fans, distributing the cool air throughout the space. This satisfies the thermostat faster, reducing the running time of air conditioning, saving you significant energy consumption. In addition, heavier cold air, caught in the corners and dead zones, is circulated back into the room ensuring all cooled areas are optimised and cooling is not wasted.

Short circuiting between supply and return section of the air conditioning system is negated too.

The use of Airius fans also enables you to increase your thermostat set point in summer or reduce it in winter and still feel the same level of comfort. That means significant energy savings for you or your client.

Heating & Warmth

As we all know hot air rises and in cold environments you lose all your heat which can be extremely costly. The Airius airflow system uses a process called "DESTRATIFICATION". In simplest terms it means capturing the lighter hot air at ceiling level and pushing it down to the floor. Airius do this by using their unique air flow pattern, to effectively and efficiently bring the warmer air back to the floor where you need it. Thermal comfort is noticeably improved and energy savings are significant. Say hello to warmer spaces and goodbye to big energy bills.

It's highly effective in both natural and air-conditioned areas. In the UK, a 3,000m² factory environment reduced their heating energy bill from £62,000 down to £21,000 in its first year. Making ROI a matter of months.

Improved Ventilation and Removing Ductwork

The Airius fans can be used to push air or smoke in or out of a building, improving naturally ventilated building designs or expelling hot air, acting as an exhaust system, (without expensive ductwork) removing humidity from inside a room or simply exchanging outside with inside air.

This feature is highly effective in industrial workplaces with excessive heat inside or outside the building.

The Airius fans ability to move either horizontally or vertically, means they can be successfully used to move and mix conditioned air, replacing air conditioning ductwork. Massive cost and energy savings are possible using this unique and proven strategy.

A light consistent breeze on the skin has the ability to significantly impact the way you feel. We have mastered airflow for your comfort. The below illustration highlights the evaporative cooling value on the body of 1.5 m/s airflow on a very hot day (35°C, 70% humidity). You can feel up to 7°C cooler through the use of precision airflow.

Cooling Airflow & Comfort Without Air-conditioning

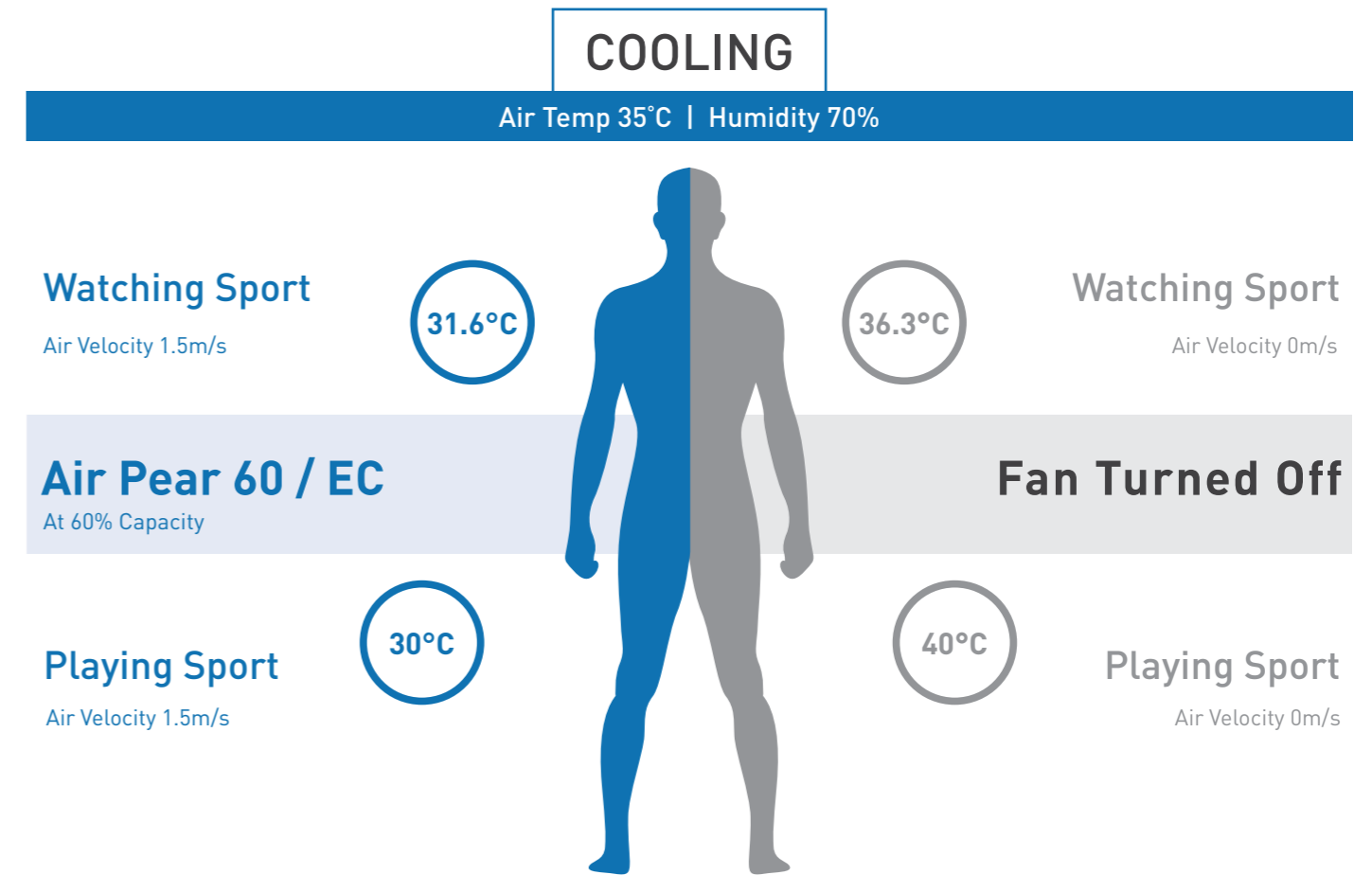

Minimal Noise Output

Airius prides itself on the incredibly low noise output of its fans.

Quieter than a church mouse.

Noise levels for each product are available on page 28.

Simple and Unobtrusive Installation

Airius have an extensive product range to meet every application. Featuring an unobtrusive sleek design and a colour or finish that blends into architectural features, Airius fans can be used in ceiling heights from 2.5m to 39m high. Installed by a licensed electrician, a solution to your heating and cooling issues can be achieved in new, existing and even heritage buildings.

How it works

Airius are the experts at air movement. The correct use of air movement and/or air removal can significantly improve personal comfort within a space, without the capital expense, running costs, health issues and carbon emissions of Air Conditioning.

Unique Airflow Creates Immediate Results

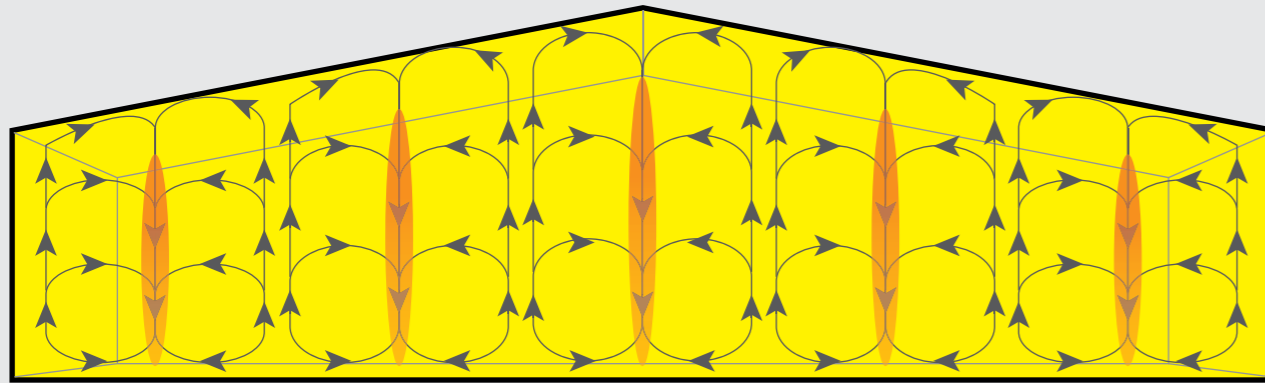

Energy efficient Airius fans are designed to work as a system

As shown above fans are, mounted just below the ceiling, (they can also be suspended metres below the ceiling if needed) evenly spaced throughout your facility, working in unison to move air efficiently around the zone of occupancy. The patented airflow technology from each fan delivers airflow to the floor which in turn interacts with other "jets" of air to create pleasant air movement and turbulence as the air flows interact.

The smoke test below clearly indicates the speed and effectiveness of the fans. Within 2 minutes you can see the smoke is evenly dispersed throughout the area.

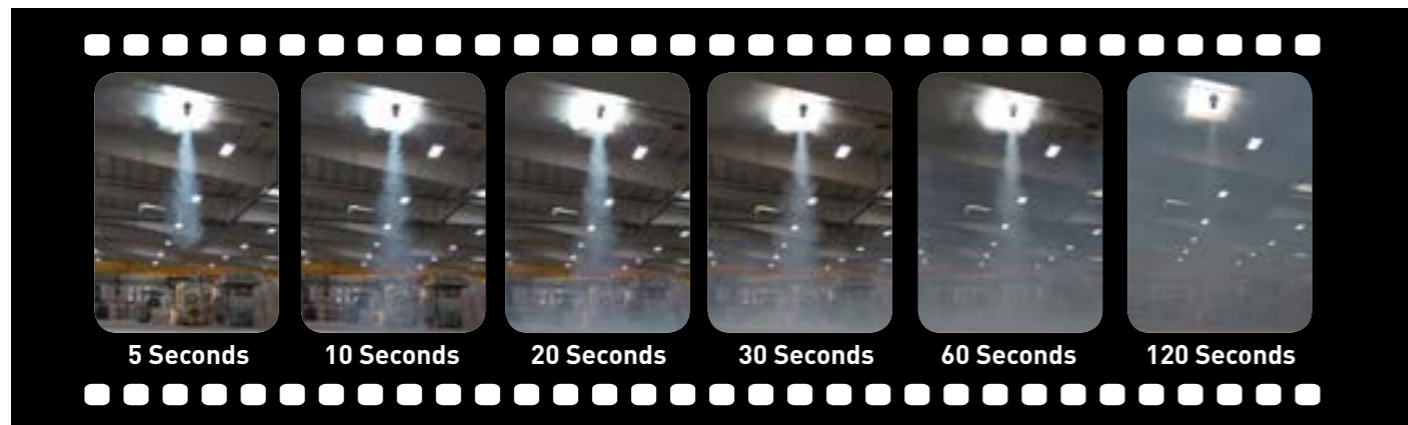

Need Technical Data?

No problem, we have specifications from page 26. Still want more? Our friendly sales team are able to send you whatever you need, it's also available right now at www.airius.com.au/technical

View conclusive fan superiority comparison videos at www.airius.com.au/videos

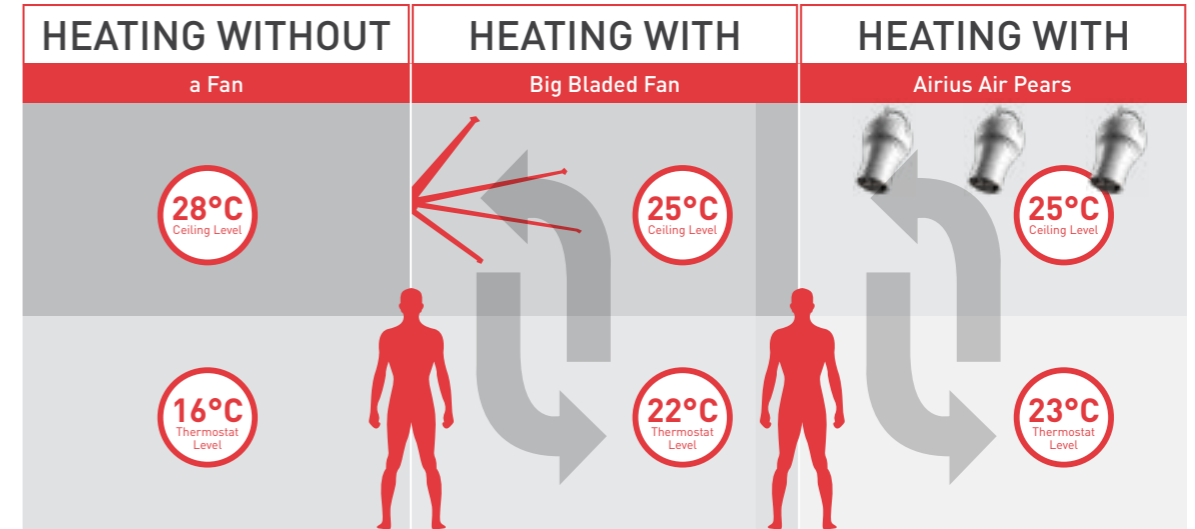

Fan Comparison Based on cooling a 40m x 20m x 9m high sports area.	Airius Fans (4 x Model G400 EC)	HVLS Fans (1 x 5.5 mts HVLS)
Product Cost incl. Install	\$12,400.00	\$14,300.00
Running Costs Per Hour @35c/wh	48 cents	52.5 cents
Unit Wattage	293 watts single phase	1.5 kw 3 phase
Total Energy Consumption	1,172 watts	1,500 watts
Eliminate Strobing	Yes	No
Maintenance Free	Yes	No
Full Replacement Warranty (no pro-rata)	Yes	No
Full Speed Or Bms Control	Yes	Yes
Low Noise	Yes	Yes
Wi-Fi Control Option	Yes	Yes
Hidden Blades	Yes	No
Unobtrusive	Yes	No
Single Phase Power	Yes	No
Can be Operational with Overhead Cranes	Yes	No
Install Height Restrictions	No	Yes
Affected By Cross Winds	No	Yes
Requires Guy Ropes	No	Yes
Requires Expensive Protective Nets / Cages	No	Yes
Needs Structural Support	No	Yes
Basketball Damage Risk	No	Yes
Dries Out Eyes	No	Yes

Unique Airflow Creates Immediate Results



Room Pre Airius Installation



Room Post Airius Installation

Patented Technology

Airius fans use air circulation and destratification airflow technology that is as equally impressive in cooling and heating applications. Ideal for winters in Tasmania and summers in Cairns.

Airius fans offer significant performance advantages to any air-conditioned application, including equalising the air temperature, removing ductwork and providing significant energy cost savings. The Airius fan range has taken the world by storm since they reinvented airflow over a decade ago.



Enhanced Airflow in All Spaces

With any fan, the spinning blades induce a rotational component into the air stream causing turbulence and reduced throw distance. Airius' patented multi-vane stator technology has reinvented the traditional fan. It uses the rotational energy to create an invisible column of air (columnar laminar flow).

This increases throw distance and enables the air to push through the thermal layers. Our patented airflow system is included as standard across all of our fans.

Airius Air Pears have an engineered Venturi throat outlet, accelerating the air speed out of the nozzle, ensuring the air flow shape is able to travel long distance and through or along the thermal layers. The patented fan casing design, not the fan blades, does most of the work hence the low energy consumption.

With the Airius systems' patented multi-vane stator technology, temperatures are balanced to within 1°C - 2°C and air flow is accelerated across and around the space as required for cooling.

Main benefits

- Reduces heating costs by 30% - 50%
- Reduces cooling costs by 5% - 30%
- Offers up to 10°C cooling in very hot summer conditions
- Can replace air conditioning ductwork for a much lower cost
- Extremely low energy consumption
- Reduces CO2 emissions by 20% - 50%
- Rapid ROI - usually between 12 -24 months
- 5 +5 years full replacement warranty
- Industry proven patented technology
- Significantly improves summer & winter comfort
- Simple to install with no ducting required
- Maintains optimum working/retail environment
- Increases lighting lifespan
- Minimal maintenance required
- Minimal running costs (from \$15/PA)
- Recycles heat from machinery, lighting, solar gain etc
- Reduces condensation
- Reduces wear on existing HVAC equipment
- Small, versatile, unobtrusive units
- Stand alone, speed controlled, BMS or wireless control options
- Works alongside all types of HVAC systems

RECOMMENDED BY THE



CONSERVATIVE ENERGY SAVINGS (%)

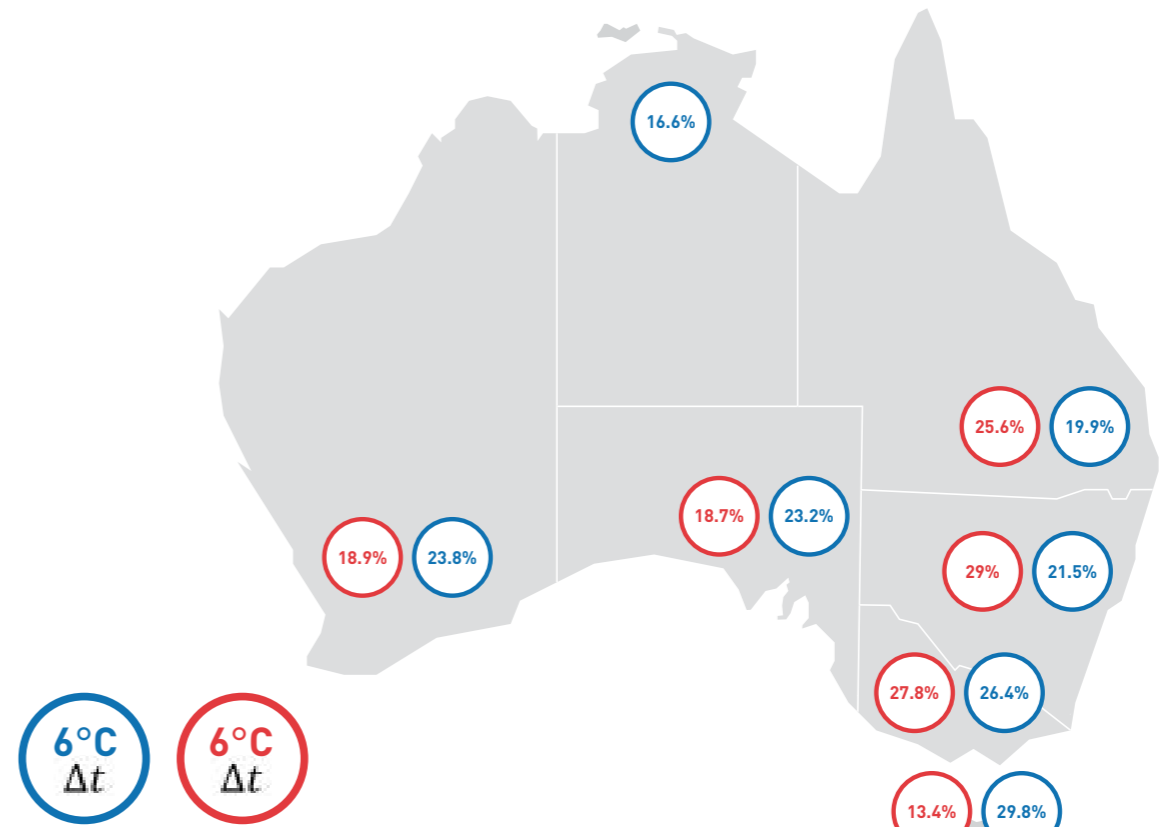

Note: The degrees noted above represent the floor to ceiling 'Delta-T' used in the software modelling.

Outcomes of the software Hourly Analysis Protocol (HAP) (HAP 4.8 software by Carrier) modelling in this report, by Dr Vahid Vaikiloroya in sub-tropical and temperate climates for a 2000 sq. metre, 4-metre-high retail space, using a water-cooled HVAC system. In real world examples in Australia (and overseas) significantly greater cooling and heating energy savings have been achieved. Returns on Investment as low as 15 months in summer cooling applications in Oceania are possible. Contact Airius to find out more.

“ The Airius Guarantee

We at Airius are so confident with the performance of our products, we offer our customers a full 90-day Money Back Guarantee - no questions asked.

If you are not happy with the units for any reason, we will refund your purchase price. Subject to a 15% restocking fee, T&C apply.

This is an offer un-matched by any other fan manufacturer and provides our customers with the all-important reassurance needed to make important decisions regarding investment. ”



View Testimonial and Case Studies.

Easy, we have provided case studies from page 34-35. In addition, you will find written and video testimonials at www.airius.com.au/testimonials

Standard Series

Known as "Air Pears"

Airius reinvented the traditional fan in 2004, revolutionising the market and creating a new standard for energy efficient cooling and heating. The market leading Standard Series, also known as an Air Pear® uses patented airflow technology to create a circular airflow pattern that is powerful enough to work in ceiling heights from 2.5m to 39m.

Engineered and architecturally designed fans blend into every location with ease and sophistication. With over 160,000 Air Pears installed globally, these sleek and energy efficient fans are saving customers thousands of dollars in energy bills and significantly reducing carbon emissions.

Ideal in all industry applications from your home through to indoor sports stadiums, school halls and all the way up to aircraft hangars, Air Pears work on their own or alongside all types of heating and cooling equipment. They are also an extremely efficient replacement for duct work.

All Air Pears are supplied in an off-white, black or grey colour. For a small extra cost, unique colours or colour schemes can also be painted onto the fans.

Depending on your model, Air Pears have the capability of cooling or equalising between 25 and 350 square metres of airflow per fan.

Airius Air Pears come in a range of motor and motor control options including the new Pear-Link™ Wi-Fi Control system.

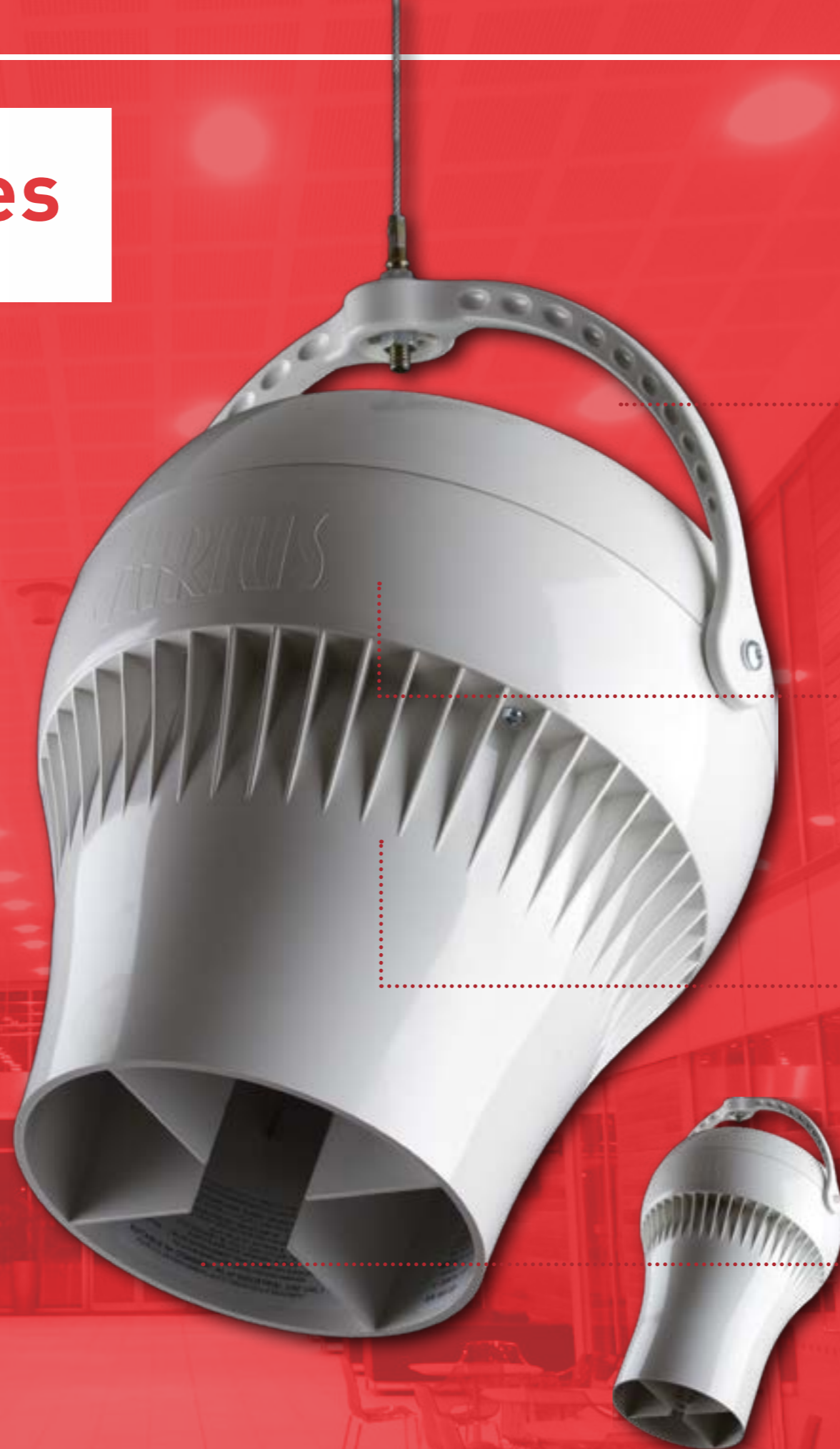
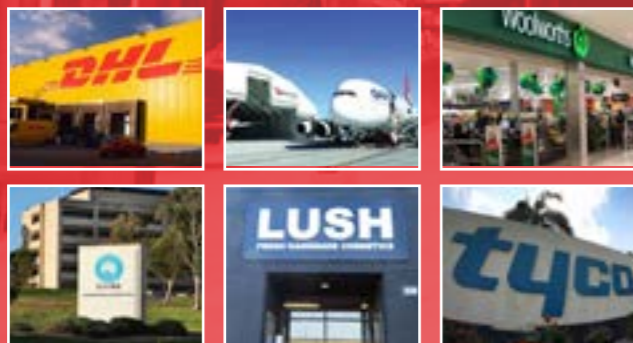

Fan Features

Adaptability

Adjustable hanging bail and eyebolt allow for the fan to be hung to blow a column of air in any direction from directly downwards to more than 90° to the floor.



Cord length

Each unit comes with a 2m power cable which can be wired into a circuit or a basic 3 pin plug (not supplied).



Leash anchor

Every unit comes with a secondary safety leash anchor point and leash cable.



Ultra Quiet

All fan motors are ultra-quiet so are suitable for sensitive environments such as offices, libraries, schools and low ceiling retail stores.



Designer Series

The Discreet Solution

The Airius Designer Series has been created to effortlessly blend into any décor or complement the architectural features of premium properties, historical landmarks, theatres and specialist spaces.

Maintaining the superior functionality and power of the Airius Air Pear, the Designer Series provides a superior airflow system in a range of airflow velocities to meet ceiling heights from 2.5m to 39m.

All Airius fans are designed to operate on a 24/7 basis for maximum efficiency and come 'plug and play' as standard. For applications looking for more control there is a range of wall mounted, variable on/ off speed controllers, or the new Wi Fi EC motor speed control system.

The new Pear-Link™ Airius Wi-Fi control module allows you to use your phone or tablet to implement a range of fan control strategies, without control cabling.

This will optimise flexibility and reduce install costs while offering ease of use.



Fan Features

Adaptability

Fans simply blend into the décor. Adaptable bail and eye bolts allow easy installation. Airflow can be angled to blow in any direction 90° vertically and 360° horizontally.

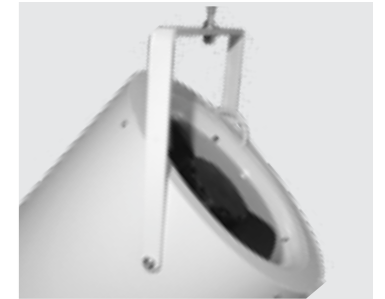

Perfect Match

When aesthetics matter Designer Series fans can be Pantone colour or finish matched to meet your space.



EC Speed Control

EC speed controllers feature an infinite speed control dial that is easy to operate, coupled with an On/Off Button and a small 'In Operation' LED light on the front of the panel.



Beautifully Made

All fans are designed and manufactured in house by Airius, ensuring quality and optimised engineering and ideal for quiet environments such as offices, retail stores, theatres, museums and libraries. That is why we can offer the 'Rock Solid' 5+5 year full replacement warranty



Retail Series

Increasing In Store Browsing

Cold shopping aisles are a profit killer for retailers. Finding the right combination of cooling for comfort and freezing for cold stock can be a costly exercise. That was, of course, before Airius brought the wonders of fan destratification to Australian retailers.

By simply installing the right fan in the right area, we help retailers:

- Increase sales
- Increase browse times
- Improve employee productivity
- Reduce wear and tear on your air-conditioning systems
- Reduce energy costs

In air-conditioned environments hot and cold spots often lead to uncomfortable areas. Installing Airius eliminates these temperature differentials and balances the temperature across the sales floor and maximises the efficiency of the AC system reducing costs by up to 30%.

Giants such as Woolworths, Coles, Aldi, IGA and Foodland all use our patented airflow technology. The benefits of destratification are well recognised within the retail sector. Not sure how it works? Just ask us for more information.



Duckbill R20EC NA
Model 20 (Narrow Aisle)



Eyeball R20 EC
Model 20 (Standard)



Fan Features

Airius fans incorporate many standard features which make them very adaptable for all types of installations.

Narrow Airflow

Another of our recently patented airflow patterns is designed for narrow cold aisles and maximises airflow down the length of an aisle for shopper comfort and energy savings, while ensuring no disturbance of the fridge cases.



Comfort & Saving

Airius Fans delicately balance the temperature throughout a store, improving the comfort of cold aisles thus increasing customer browse time and impulse purchases.



Before Airius

- Eliminates cabinet glass fogging
- Dries spills quickly
- Increases lighting lifespan
- Optimises all HVAC systems & reduces maintenance costs
- Recycles heat from equipment, solar gain, lighting etc.
- Condensation is reduced or eliminated.



After Airius

Gem Series

G-Force Velocity for Large Open Spaces

NEW

The bigger and hotter the space the more a breeze feels like a slice of heaven. Airius have exceeded market and airflow expectations with the exciting G400 fan and soon to be released G560 fan (due for release October 2019). You can say goodbye to uncomfortable large open spaces, the reinvention of the fan just got serious!

When Airius developed the G400, ideal for open air spaces from 7-12m high, we thought we had outdone ourselves. It's immediate and overwhelming success pushed us (again) to find a cooling solution for even bigger spaces or those wanting massive volumes of air flow. We applied our patented airflow technology to new limits to create the G560, ideal for open air spaces between a whopping 8-16 metres high. Utilising our recently developed and patented 'Bypass Technology', we internally call it the "mother of all fans"

We really have reinvented a fan system that will ensure occupants of large internal spaces will be comfortable in blistering Australian conditions.

The Gem series is ideal for sports halls, warehouses, manufacturing, entertainment centres, railway stations, aircraft hangars, indoor and outdoor stadiums.

Don't fear, with an Airius fan, size doesn't mean you have to compromise with noise levels. The G400 and the G560 are extremely quiet for the volume and velocity of air they discharge.

Book a demo for yourself.

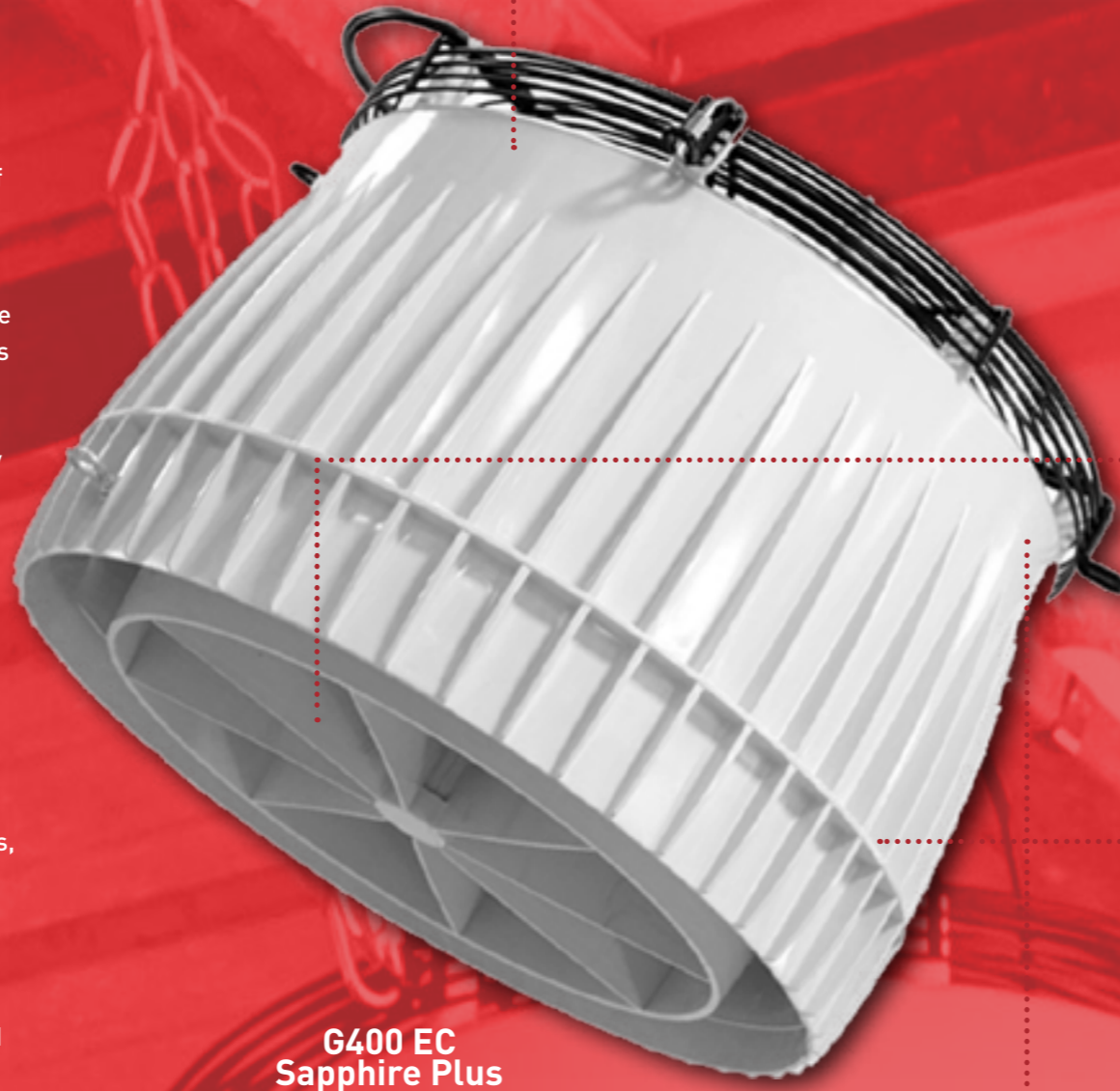

G400 EC
Sapphire Plus



Fan Features

Bypass Technology

The G560 uses our new patented bypass technology that applies the same aerodynamic features as Dreamliner jet engines. Capturing and propelling large volumes of air through the system for your cooling pleasure.

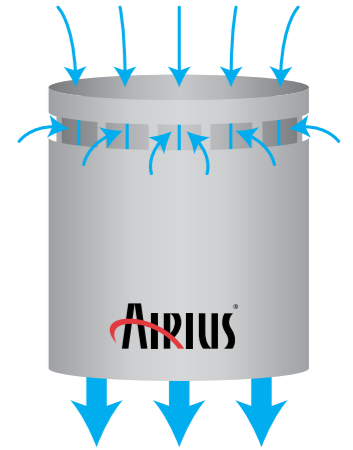

Huge Airflow

A massive centreline velocity of 2.9 m/s @ 10 metres is achieved with the powerful G400 fan. Plus a thrust of 14.89 Newtons!



Strong as an Ox

These fans, like all Airius fans are incredibly strong. They have been designed to endure the hottest of Australian conditions, where others melt and to withstand the impacts from any type of sports projectiles.



Still Single Phase

That's right, while others increase your costs with 3 phase power, these units are still conveniently single phase, with the G560 EC using a maximum of 364 watts @ 230 volts.



Suspended Series

Cooling or Heating Low Profile Areas

Seamlessly designed for suspended, dropped or false ceilings, the Airius Suspended Ceiling Kits are a discreet and unobtrusive solutions that fits into a standard metric ceiling tile dimension.

Airius can supply a fan and ceiling kit to suit any height and type of suspended ceiling grid. The kit which contains a self containing dome ensure that only the zone of occupancy is serviced by the fan within the kit whilst not protruding noticeably below the ceiling line. The ceiling kit can suit all variants of the 10, 15, 25 and 45 fan models in any colour.

Major supermarkets like Walmart, TESCO, Sainsbury, Marks & Spencer's, Meijer and HEB all use Airius. Closer to home look up when in Woolworths, Coles, Aldi and Kmart.

These models can also be used in libraries, offices, theatres, classrooms, car showrooms etc. to provide comfort across the year or to reduce the energy use of your air conditioning or heating system.

Also custom designs for all ceiling types can be created to suit all Airius fan types.



Fan Features

Airius fans incorporate many standard features which make them very adaptable for all types of installations.

Discreet Profile

Airius fans with ceiling kits are suitable for buildings with a ceiling height of 2.5 metres up to 11 metres and are easily adaptable to changing floor plans.



Low Profile

Fans require a minimum ceiling void of 270mm – 460mm (depending on model).



Weight & dimensions

Note: Standard Series fan nozzles will protrude from the face plate to different lengths depending upon the model. See below:

- Model 10 (Short) = 120mm
- Model 10, 15 & 25 = 222mm
- Model 45 = 219mm

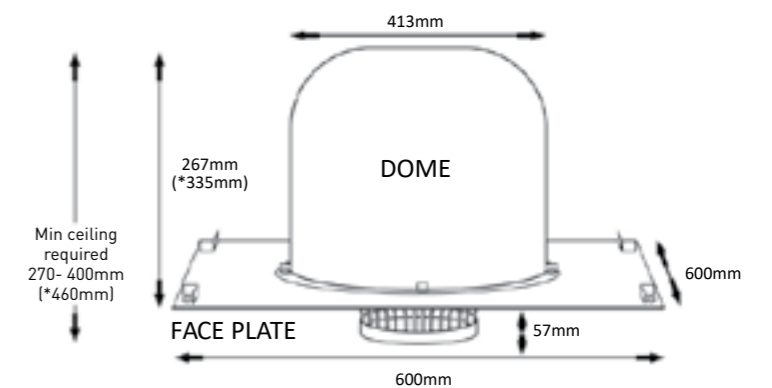

Weight = 3.6kgs (*4kgs) | Ceiling Height = 2.5m - 15m
 Housing = Recycled PC/ABS Resin (5VA flame resistance rating)
 Colour = Off White, Black or Grey (Can be colour match painted to your specifications)

*Applies to Model 45 Suspended Series Kit

Quiet Series

For Noise Sensitive Applications

The Airius Q Series takes noise management to a new level. Redesigned applying acoustic research and expertise to our patented airflow technology, the Q Series has developed a new standard in acoustic management and architectural aesthetic.

Ideal for theatres, school, shopping centres, offices and entertainment centres, the Q Series is an exciting edition to the Airius range.

Solve comfort issues, increase productivity, save on HVAC energy costs and reduce your carbon footprint. Working in concert, each Q Series fan delivers gentle efficient air circulation to balance overall air temperature from ceiling to floor and wall to wall. Available in two motor types to suit ceiling height requirements up to 13.5m.

The ratcheted handle allows the fan to be angled and locked in position. An eyebolt is provided for hanging the fan using a beam clamp/bridle ring, chain-link/carabiner or similar method. Refer to installation, operation and maintenance guide for further details.

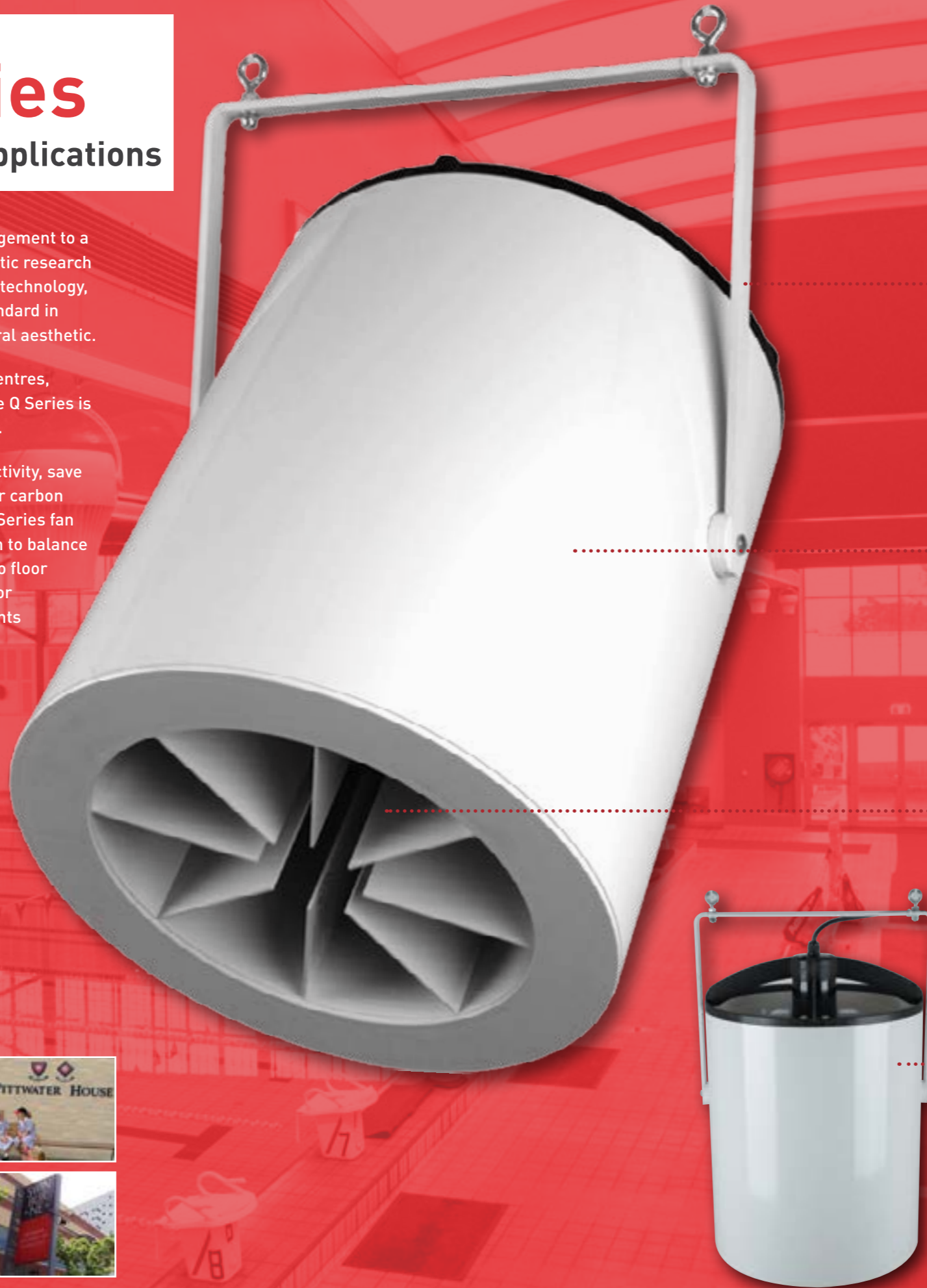

Fan Features

Adaptability

Ratcheted metal handle allows fan to be angled and locked in position. Eyebolt provided for hanging the fan using beam clamp/bridle ring, chain-link/ carabiner or similar method.



Assorted Control Options

Can be controlled by BMS, potentiometer, transformer speed control or the new Pear- Link™ WIFI Ipad / Phone remote control system.



Motor Options

Like most Airius fans the Q Series uses the worlds best EBM Papst EC/ PS-4 motor options. This allows trouble free and reliable air circulation & destratification up to a ceiling height of 13.5m.



Full Redesign

The Q Series redesign has moved the motor position so it sits lower in the Q50 ensuring air flow is optimised with no need for noise inducing grilles.



Pearl Series

NEW

Not too big, Not too small

The market spoke and we listened. The Pearl Series has been created to meet two industry needs:

- Provide an option for small - medium size spaces that would need a few too many fans for aesthetics, while too small a space for a Large Spaces series fan and
- Provide a small white powerful and quiet new fan where we could manufacture our patented airflow technology at a market entry price.

This beautifully designed small fan effortlessly pushes air around spaces with ease. Looking at its compact design you could not imagine its airflow ability. Pushing out and recycling air in an effortless way, while maintaining the Airius design standard of being incredibly quiet.

Ideal for spaces from 2.5- 6.5 metres high, the Pearl will become a treasured feature of any room or application.

The Pearl is ideal for supermarkets, classrooms, storage facilities, garages, art galleries, houses, museums etc.

The Pearl comes in four motor types: - S1, S2, EC single speed and EC with potentiometer or Wi-Fi Pear-Link™ Speed control.



Opal Series

NEW

Reinventing home cooling

Ever laid on the couch wishing your seat was directly under the fan, but it wasn't. Sad, right? Or wished the big fans in the middle of your house were less imposing? Or wondered what it would be like to not nag the kids about jumping on their beds for fear of injury?

With an Airius Opal fan, these are concerns of the past.

Using the range of Opal fans for your home means:

Say goodbye to dust collecting on blades

- No risk of children jumping into the blades from their beds
- No lighting redesigns needed
- No strobing issues for sensitive children or aged care inhabitants
- Small, unobtrusive units
- Small enough models for bath rooms
- Low noise and high efficiency
- Very low energy use
- Lightweight and easy to install
- Factory adjustable 2 speed wall or case mounted control
- Excellent for aged care bedrooms or hotel rooms
- Can be wall, ceiling or floor mounted



ONYX Series

NEW

A leap in technology for your cooling pleasure

The Onyx is the evolution of our already world leading airflow technology. The newly engineered and patented airflow methodology applies the same airflow optimisation technology as the new generation of jet engines used in Boeing Dreamliners. Capturing and propelling large volumes of air through the system for your cooling pleasure.

We call this unique and exciting design 'Bypass Technology™'. The architecture of the fan case increases the air draw through suction, maximising the air volume bypassing the fan motor, exponentially increasing air flow performance.

Imagine if you will a fan able to powerfully distribute air, that is quieter than any in its size with a beautiful aesthetic to rival our premium Designer Series. We have taken the best of all of our fans to create a series that pushes the general consensus of what a fan can achieve. All at a very low cost.

Ideal for spaces from 4-8 metres high, the Onyx is ideal in schools, bleachers, retail precincts, theatres, art galleries, lecture theatres, big box retailers, offices, foyers etc.

Book your demo today.



Fan Features

Motor Options

The unique engineered slots in the fan casing, combined with assorted other engineering initiatives and the proven Airius internal air turbine design, enable the Onyx to reinvent air flow capability once more. The Onyx is available in both P4 or EC Ebm -Papst world's best German fan motors.



Bypass Technology™

The Onyx uses our new patented bypass technology that applies the same aerodynamic features as the latest Dreamliner jet engines. Capturing and propelling large volumes of air through the system for your cooling pleasure.

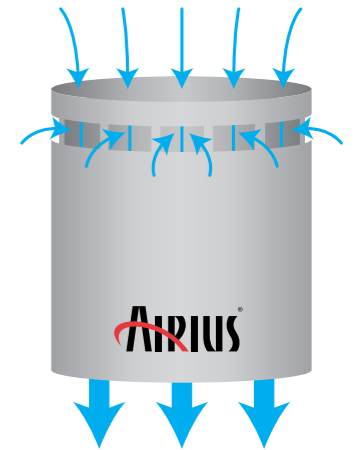

Our product range

Explore the world's most versatile and energy efficient range of fans. The Airius airflow system has created a new standard in air circulation, no matter your internal space, we have a fan that will change your view of fans forever. Enjoy effortlessly circulated air that is carbon efficient and incredibly cost effective. Saving you from 20-50% of energy costs.

Standard Series



Designer Series



Retail Series



Gem Series



Onyx Series



Suspended Series



Unit Dimensions & Weights

	Weight	Diameter	Height (to Rim)	Height (Total)
Standard Series				
Model 10 (Short)	3.2 KG	325 MM	311 MM	444 MM
Model 10	4.1 KG	325 MM	413 MM	546 MM
Model 15	4.1 KG	325 MM	413 MM	546 MM
Model 25	4.1 KG	325 MM	413 MM	546 MM
Model 25/EC	4.1 KG	325 MM	413 MM	546 MM
Model 45/PS-4	6.3 KG	375 MM	455 MM	605 MM
Model 45/PS-2	6.3 KG	375 MM	455 MM	605 MM
Model 45/EC	6.3 KG	375 MM	455 MM	605 MM
Model 60/PS-4	15 KG	498 MM	607 MM	823 MM
Model 60/EC	15 KG	498 MM	607 MM	823 MM
Model 100/EC	20.4 KG	495 MM	N/A	843 MM
Designer Series				
Model 10 (Short)	5.4 KG	333 MM	299 MM	436 MM
Model 10	6.8 KG	333 MM	400 MM	538 MM
Model 15	6.8 KG	333 MM	400 MM	538 MM
Model 25	6.8 KG	333 MM	400 MM	538 MM
Model 45/PS-4	8.6 KG	373 MM	452 MM	610 MM
Model 60/PS-4	17.2 KG	492 MM	610 MM	838 MM
Model 60/EC	17.2 KG	492 MM	610 MM	838 MM
Model 125/EL	45.3 KG	690 MM	N/A	938 MM
Retail Series				
Model 20/EC (Standard)	5.2 KG	366 MM	254 MM	406 MM
Model 20/EC (Narrow Aisle)	5.2 KG	366 MM	331 MM	480 MM
Quiet Series				
Model 50/PS-4	9.9 KG	387 MM	435 MM	584 MM
Model 50/EC	9.9 KG	387 MM	435 MM	584 MM
Suspended Series				
Model 10, 15, 25 (3 per box)	3.6 KG	600 MM	600 MM	324 MM
Model 45 (2 per box)	4.0 KG	600 MM	600 MM	392 MM
GEM Series				
G400	14.0 KG	330 MM	495 MM	495 MM
PEARL Series				
Pearl S1	3.0 KG	286 MM	229 MM	280 MM
Pearl S2	3.0 KG	286 MM	229 MM	280 MM
Pearl EC	3.0 KG	286 MM	229 MM	280 MM
OPAL Series				
Domestic Model	2.0KG	240 MM	105 MM	165 MM

Technical Data

At the heart of most Airius fans is a top of the range, highly efficient, German EBM-Papst motor. Independently tested by BSRIA they provide the most efficient and effective cooling air movement or destratification available.

What makes Airius fans the most effective method of air circulation cooling and destratification available is the synergy between motor efficiency, the unique patented method of airflow distribution created by the 'Stator Vanes' combined with the Venturi throat, and the way the units use the laws of thermodynamics to work in their favour. All with no exposed blades!

There are a wide range of units available to suit almost any application. Refer to the data below for a guide to what unit/s you need in your building.

No other fan can move as much air as far and as efficiently.

	Model 10	Model 15	Pearl S1	Pearl EC
Range	Standard & Designer	Standard & Designer	Hybrid	Hybrid
Ceiling Heights¹	2.5m - 4m	2.5m - 6m	2.5m- 6m	2.5m-6.5m
Floor Area¹	30m ² - 50m ²	30m ² - 90m ²	25m ² - 80m ²	25m ² -90m ²
Volts²	230	230	230	230
Watts²	13.5	17.4	28.4	34.7
RPM²	868	1154	1400	1579
L/S	150	191	216	295
AMPS²	0.06	0.077	0.126	0.14
IP Rating	IP55	IP55	IP55	IP55
Operating Temp²	-20°C - 70°C	-20°C - 70°C	-20°C - 70°C	-30°C - 50°C
Thermal Shut Off¹	110°C	110°C	110°C	110°C
Reset Temp²	90°C	90°C	90°C	90°C
Sound Pressure Level @3 mts d(B)A³	33	33	40	51

¹ Dimensions noted here are for both cooling and heating options. Contact Airius for the best solution.

² Motor data provided by motor manufacturer during in-situ testing and is subject to change at any time.

³ Sound Pressure Level recorded at full speed.

“ Energy Efficiency... ”

...is at the heart of everything we do. Not only to save our customers money, but also to help provide business with the latest technology to reduce their energy consumption and lessen our ever growing impact on the environment.

Unit Coverages, Motor Data & Noise Levels

	Model 20/EC	Model 20/EC-S	Model 25	Model 25/EC	Model 45/PS-4	Model 45/PS-2
Retail - Narrow Aisle	Retail - Standard	Standard & Designer	Standard	Standard & Designer	Standard	
2.5m - 6m	2.5m - 7m	3m - 8m	3m - 9m	6m - 10m	6m - 14m	
Contact Airius	30m ² - 100m ²	30m ² - 120m ²	40m ² - 133m ²	40m ² - 133m ²	80m ² - 150m ²	
230	230	230	230	230	230	
34.7	35	28	31	45.4	132	
1586	1579	1405	1640	1354	2300	
292	292	216	292	280	505	
0.14	0.14	0.123	0.13	0.2	0.57	
IP54	IP54	IP55	IP55	IP44	IP44	
-30°C - 50°C	-30°C - 50°C	-20°C - 70°C	-30°C - 50°C	-25°C - 70°C	-25°C - 50°C	
110°C	110°C	110°C	110°C	135°C	135°C	
90°C	90°C	90°C	90°C	125°C	125°C	
48	47	40	51	38	63	

Each facility has unique fluid dynamics, please contact supplier to specify your system. Data above is independently tested at 50Hz. Accurate as of April 2019.

Technical Data

Continued

System Speed Controls

All Airius systems are designed to operate on a 24/7 basis for maximum efficiency and come 'plug and play' as standard. Where more flexibility is required we provide a range of wall mounted, variable on/off five step speed controllers for our non EC motors. Controllers can only be installed onto circuits of the same Airius model.

The EC controller is suitable for Airius EC models only. The EC potentiometer speed controller offers a continuous 0-100% speed control capability.

1 Amp Controller

- 16 x Airius Model 10's
- 13 x Airius Model 15's
- 6 x Airius Model 25's
- 4 x Airius Model 45/PS-4's
- 1 x Airius Model 45/PS-2
- 1 x Airius Model 60/PS-4

5 Amp Controller

- 83 x Airius Model 10's
- 66 x Airius Model 15's
- 32 x Airius Model 25's
- 23 x Airius Model 45/PS-4's
- 8 x Airius Model 45/PS-2's
- 8 x Airius Model 60/PS-4's

	Model 45/EC	Model 50/PS-4	Model 50/EC	Onyx P4	Onyx EC
Range	Standard	Quiet	Quiet	Onyx	Onyx
Ceiling Heights¹	8m - 15m	5m -12m	5m - 15m	4m -12m	4m - 15m
Floor Area¹	80m ² - 160m ²	50m ² - 150m ²	60m ² - 200m ²	60m ² - 150m ²	60m ² - 200m ²
Volts²	230	230	230	230	230
Watts²	153	65	87	65	87
RPM²	2789	1375	1669	1375	1669
L/S	615	500	637	500	637
AMPS²	1.93	0.295	0.36	0.295	0.36
IP Rating	IP44	IP44	IP44	IP44	IP44
Operating Temp²	-25°C - 60°C	-25°C - 70°C	-25°C - 70°C	-25°C - 70°C	-25°C - 70°C
Thermal Shut Off¹	135°C	135°C	135°C	135°C	135°C
Reset Temp¹	125°C	125°C	125°C	125°C	125°C
Sound Pressure Level @3 mts d(B)A³	68	48	56	48	56

¹ Dimensions noted here are for both cooling and heating options. Contact Airius for the best solution.

² Motor data provided by motor manufacturer during in-situ testing and is subject to change at any time.

³ Sound Pressure Level recorded at full speed.



Series warranty

All Airius Destratification fans come with a Rock Solid 5+5 year Replacement Warranty (terms and conditions apply). Simply return defective units to Airius, carriage paid and upon receipt Airius will dispatch a new unit by return carriage fully paid.

To avoid refurbishment and cleaning charges, all units returned must adhere to the returns criteria.

For further details email info@airius.com.au or call on +61 (2) 6608 2736.

Model 60 P4	Model 60/EC	Model 100/EC	Model 125/EL	Model 400 EC	Model 400 P4	Model 560 EC
Standard and Designer	Standard & Designer	Standard	Designer	Gem	Gem	Gem
6m-15m	6m - 20m	8m-25m	12m-30m	7m-15 m	6m-13m	7m-20 m
80m ² - 170m ²	80m ² - 232m ²	100m ² - 270m ²	150m ² - 335m ²	100m ² - 250 m ²	80m ² - 200m ²	150m ² - 300m ²
230	230	230	200-277	230	230	200-277
126	143	293	364	293	160	364
1346	1605	1517	1006	1517	1430	1006
575	786	1584	2500	1584	1129	2500
0.58	0.59	1.22	1.59	1.22	0.73	1.59
IP44	IP44	IP54	IP54	IP54	IP54	IP54
-25 -70°C	-25°C - 60°C	-25°C - 60°C	-25°C - 60°C	-25°C - 60°C	-25°C - 60°C	-25°C - 60°C
135°C	135°C	135°C	135°C	135°C	135°C	135°C
125	125°C	125°C	125°C	125°C	125°C	125°C
54	56	63	61	63	58	61

Each facility has unique fluid dynamics, please contact supplier to specify your system. Data above is independently tested at 50Hz. Accurate as of April 2019.



**VARIOUS
FINANCE
PACKAGES
AVAILABLE...
ASK US!**



**“STRATIFICATION IS
THE SINGLE BIGGEST
WASTE OF ENERGY IN
BUILDINGS TODAY**
Dr. Byron Jones, PhD, MS, BS, ASHRAE

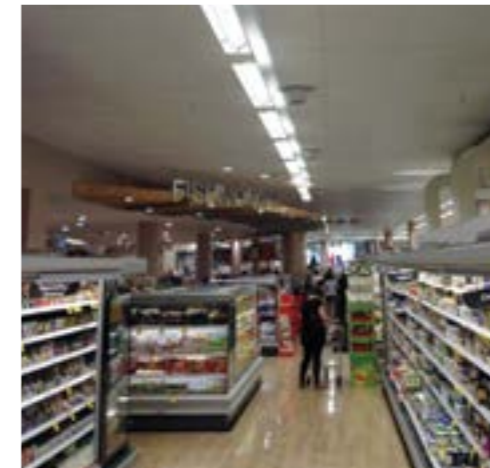

**DISCOVER OUR CASE STUDIES &
EXPLORE REAL-WORLD GAINS
FROM REAL-WORLD CLIENTS...**
www.airius.com.au/testimonials
>>>>



Testimonials

“We loved the cost, and authentically they look really good in the space. The school absolutely loves them, we are really really pleased.”

Pittwater House

“We ran a trial in an IGA – the results were amazing and defied all the sceptics. Customers noted improvement in cold aisle temperatures immediately. Temperatures throughout the store became more balanced and they had NO impact on refrigeration running costs.”

Optimum Control Technologies

“The fans are going really well. We’ve got lots of compliments about them around the school and I really do enjoy how they blend in with the ceiling – you hardly know they are there.”

Springfield Central State High School

““ The Domestic Unit is fantastic! It’s absolutely perfect for the application...I really think the product should be given a lot more publicity. ””

Centrum Architects

“The space is a lot more usable in the hotter summer months. We have received great feedback from both the school PE department and also external hirers.”

SCEGGS Darlinghurst

“We found the Airius fans to be quiet, efficient and we noticed they moved the air around the space effortlessly and are very good at balancing the temperature in our large space. That was important for us. They are also inconspicuous hanging with our high bay lighting which suits our new architectural facility beautifully.”

Kilmore Toyota



“The G400’s work very well. The teachers and students are very happy with the outcome and also advised they move a lot of air around!”

Cairns High School QLD, Contract Electrician & Installer

“Wow what a difference some G400 fans make in our two-court stadium. The fans have made a massive difference to the air flow, comfort levels and PR at the Warwick Indoor Recreation and Aquatic Centre (WIRAC). It’s quite remarkable the way the fans work as a “system” and create a more pleasant environment for our wide range of users in our Centre. Great service from Airius, great product and great value.”

PCYC Warwick

““ We were pretty surprised by how good they have been...the biggest success is in shooting down the picking aisles.” - “At 35 Deg. C and humid it was really good. ””

Lush Cosmetics



AIRIUS[®]

**For a free design and
quotation contact us at:**

Australia & New Zealand

P.O. Box 1812, Byron Bay, NSW, 2481
info@airius.com.au
+61 (0) 401 848 888

North America

811 S.Sherman St, Longmont, CO
info@airiusfans.com
888-247-7327

Europe

Holwell Farm, Cranbourne, Dorset, UK
airflow@airius.co.uk
+44 (0) 1202 554200

Visit us at www.airius.com.au

AIRIUS[®], AIR PEAR[®], and THE THERMAL EQUALIZER[®] are trademarks of Airius LLC, registered in the U.S. and in some countries abroad.

Other trademarks pending in the U.S. and abroad. May be covered by one or more of the following United States Patents: 7,381,129 B2; D514688 and other patents pending.